

---

# **LASER SYSTEMS FOR APPLICATIONS**

---

Edited by **Krzysztof Jakubczak**

**INTECHWEB.ORG**

## **Laser Systems for Applications**

Edited by Krzysztof Jakubczak

### **Published by InTech**

Janeza Trdine 9, 51000 Rijeka, Croatia

### **Copyright © 2011 InTech**

All chapters are Open Access distributed under the Creative Commons Attribution 3.0 license, which allows users to download, copy and build upon published articles even for commercial purposes, as long as the author and publisher are properly credited, which ensures maximum dissemination and a wider impact of our publications. After this work has been published by InTech, authors have the right to republish it, in whole or part, in any publication of which they are the author, and to make other personal use of the work. Any republication, referencing or personal use of the work must explicitly identify the original source.

As for readers, this license allows users to download, copy and build upon published chapters even for commercial purposes, as long as the author and publisher are properly credited, which ensures maximum dissemination and a wider impact of our publications.

### **Notice**

Statements and opinions expressed in the chapters are these of the individual contributors and not necessarily those of the editors or publisher. No responsibility is accepted for the accuracy of information contained in the published chapters. The publisher assumes no responsibility for any damage or injury to persons or property arising out of the use of any materials, instructions, methods or ideas contained in the book.

**Publishing Process Manager** Petra Nenadic

**Technical Editor** Teodora Smiljanic

**Cover Designer** InTech Design Team

**Image Copyright** pixomar, 2011.

First published December, 2011

Printed in Croatia

A free online edition of this book is available at [www.intechopen.com](http://www.intechopen.com)  
Additional hard copies can be obtained from [orders@intechweb.org](mailto:orders@intechweb.org)

Laser Systems for Applications, Edited by Krzysztof Jakubczak

p. cm.

ISBN 978-953-307-429-0

---

# Contents

---

## **Preface IX**

### **Part 1 Laser and Terahertz Sources 1**

Chapter 1 **Q-Switching with Single Crystal Photo-Elastic Modulators 3**  
F. Bammer, T. Schumi, J. R. Carballido Souto, J. Bachmair,  
D. Feitl, I. Gerschenson, M. Paul and A. Nessmann

Chapter 2 **Acousto-Optically Q-Switched CO<sub>2</sub> Laser 17**  
Jijiang Xie and Qikun Pan

Chapter 3 **Mode-Locked Fibre Lasers with High-Energy Pulses 39**  
S.V.Smirnov, S.M. Kobtsev, S.V.Kukarin and S.K.Turitsyn

Chapter 4 **All-Poly-Crystalline Ceramics Nd:YAG/Cr<sup>4+</sup>:YAG Monolithic  
Micro-Lasers with Multiple-Beam Output 59**  
Nicolai Pavel, Masaki Tsunekane and Takunori Taira

Chapter 5 **Laser Pulses for Compton Scattering Light Sources 83**  
Sheldon S. Q. Wu, Miroslav Y. Shverdin,  
Felicie Albert and Frederic V. Hartemann

Chapter 6 **Frequency-Tunable Coherent THz-Wave Pulse  
Generation Using Two Cr:Forsterite Lasers with  
One Nd:YAG Laser Pumping and Applications for  
Non-Destructive THz Inspection 119**  
Tadao Tanabe and Yutaka Oyama

### **Part 2 Laser Beam Manipulation 137**

Chapter 7 **Laser Pulse Contrast Ratio Cleaning in 100 TW Scale Ti:  
Sapphire Laser Systems 139**  
Sylvain Fourmaux, Stéphane Payeur, Philippe Lassonde,  
Jean-Claude Kieffer and François Martin

Chapter 8 **Controlling the Carrier-Envelope Phase of Few-Cycle  
Laser Beams in Dispersive Media 155**  
Carlos J. Zapata-Rodríguez and Juan J. Miret

- Chapter 9 **Laser Beam Shaping by Interference: Desirable Pattern** 171  
Liubov Kreminska
- Chapter 10 **Nonlinear Pulse Reshaping in Optical Fibers** 185  
S. O. Iakushev, I. A. Sukhoivanov, O. V. Shulika,  
J. A. Andrade-Lucio and A.G. Perez
- Part 3 Intense Pulse Propagation Phenomena** 207
- Chapter 11 **Linear and Nonlinear Femtosecond Optics in Isotropic Media - Ionization-Free Filamentation** 209  
Kamen Kovachev and Lubomir M. Kovachev
- Chapter 12 **Dispersion of a Laser Pulse at Propagation Through an Image Acquisition System** 227  
Toadere Florin
- Chapter 13 **Third-Order Optical Nonlinearities of Novel Phthalocyanines and Related Compounds** 253  
Zhongyu Li, Zihui Chen, Song Xu, Xinyu Zhou and Fushi Zhang
- Chapter 14 **Broadband Instability of Electromagnetic Waves in Nonlinear Media** 271  
Sergey Vlasov, Elena Kuposova and Alexey Babin
- Part 4 Metrology** 289
- Chapter 15 **Quantification of Laser Polarization by Position Dependent Refractive Indices** 291  
Yong Woon Parc and In Soo Ko

# Mode-Locked Fibre Lasers with High-Energy Pulses

S.V.Smirnov<sup>1</sup>, S.M. Kobtsev<sup>1</sup>, S.V.Kukarin<sup>1</sup> and S.K.Turitsyn<sup>2</sup>

<sup>1</sup>*Novosibirsk State University*

<sup>2</sup>*Aston University*

<sup>1</sup>*Russia*

<sup>2</sup>*UK*

## 1. Introduction

The recent explosive development of the physics and technology of fibre lasers as well as a vast expansion of their application areas greatly stimulate the quest for and the study of more advanced operational modes of such lasers, including generation of ultra-short and high-energy pulses. Since the invention of the laser researchers have continuously strived to generate shorter laser pulses. Simultaneously achieving a short duration and a high pulse energy is certainly more challenging than improving one of these parameters independently. However, it is this combination that becomes increasingly important in a wide range of scientific, technological, medical, and other applications. High energies and ultra-short pulse durations are both associated with high field intensity that often makes physical system non-linear. In fibre lasers, there are specific properties relevant to both shortening of the pulse duration and increasing their energy. The main obstacles on the road to shorter pulses are a relatively high dispersion and non-linearity of fibre resonators. In addition, the path to high-energy ultra-short pulses is, typically, further complicated by relatively low energy damage thresholds of standard fibre components, such as splitters, isolators, and so forth. While the effects of dispersion can be compensated by different rather advanced means, the nonlinear effects in fibres are much more difficult to manage. Thus, nonlinearity plays a critical role in the design of advanced fibre laser systems, but paradoxically, it is somewhat undesirable to many engineers because of its very limited controllability. Substantial efforts have been made to reduce the resonator nonlinearity, *e.g.* by using large-mode-area fibres, and this direction presents an important modern trend in laser technology. On the other hand, understanding and mastering nonlinear physical fibre systems offer the potential to enable a new generation of laser concepts. Therefore, it is of great importance to study physics and engineering design of laser systems based on nonlinear photonic technologies. In particular, new nonlinear approaches and solutions pave a way for development of advanced mode-locked fibre lasers with ultra-short high-energy pulses.

Presently, passive mode locking is one of the key methods of ultra-short pulse (USP) generation. As recently as a few years ago, femto- and pico-second pulses extracted directly from the master oscillator operating in a passive mode-locking regime had relatively low energies, typically, not exceeding at few dozens of nJ and, in some special cases, hundreds

of  $nL$ . In order to radically boost the pulse energy, additional optical amplifiers were used or, otherwise, a completely different method of short pulse generation, Q-switch was employed, which allowed considerably higher per-pulse energy, albeit at the expense of longer duration, typically, over several nanoseconds and more.

The combined Q-switching and mode locking in one cavity has also been successfully employed for generation of high-energy pulses of laser radiation (Lin *et al* 2008, Jabczyński *et al*, 2006). Another way to increase per-pulse energy of output radiation is the cavity dumping technique (Johnson *et al*, 1976), which can be used in all the mentioned above types of lasers. In order to increase the intra-cavity pulse energy, the cavity dumping method uses a closed multi-path resonator, into which a so-called cavity dumper is inserted that allows picking single high-energy pulses out of the cavity at a frequency lower than the original pulse repetition rate. More powerful pump sources may also increase per-pulse energy in passively mode-locked lasers, but this may be achieved with certain combinations of pulse and cavity parameters only (Akhmediev *et al*, 2008; Chang *et al*, 2008). Another method traditionally utilised in most high-energy laser systems of different types relies on extra-cavity optical amplification.

A completely different physical approach to achieving higher energy of USP generated in lasers with passive mode locking is based on elongation of the laser cavity. The pulse repetition rate of a mode-locked laser is inversely proportional to its resonator length, this is why using longer cavities leads to lower pulse repetition rate and, consequently, to higher pulse energy at the same average output power. The following simple relation describes this design principle:

$$E_p \propto P_{ave} T_R \propto P_{ave} nL/c.$$

Here  $E_p$  is the pulse energy of a mode-locked laser, and  $P_{ave}$  is the average radiation power,  $T_R$  is the resonator round trip time,  $n$  – the refraction index of the cavity medium,  $c$  – the speed of light,  $L$  – the resonant cavity length. This method is well suited for fibre lasers whose resonator length may reach dozens (Ania-Castañón *et al*, 2006; Ivanenko *et al*, 2010) and even hundreds of km (Ania-Castañón, 2009). This allows generation in mode-locked lasers of the highest-energy pulses possible for this type of lasers. Of course, this high pulse energy coming out of the master oscillator can be further increased in an optical amplifier.

The first studies of long mode-locked fibre lasers performed by many research groups around the world showed that the simultaneous solution of the problems of short duration of pulses and of their relatively high energy is a non-trivial task. In this chapter, we will discuss the physical conditions required for high-energy pulse generation as well as the problems and limitations related to cavity lengthening up to several kilometres or even dozens of kilometres. We will consider the physical mechanisms of mode locking including new types of mode locking that takes place in such lasers. We will overview the recent publications in this rapidly growing area and will analyse the prospects of long-resonator mode-locked fibre lasers.

## 2. Review of recent progress in mode-locked fibre lasers with high-energy pulses

First experiments on considerable cavity elongation up to 100 and 400 m in solid-state (Kolev *et al*, 2003) and fibre (Kang *et al*, 1998; Fong *et al*, 2006; Fong *et al*, 2007) mode-locked lasers have shown that in such relatively long resonators, it is possible to achieve stable

passive mode locking. As a result, the pulse repetition frequency can be reduced by more than an order of magnitude (down to  $\sim 1.7$  MHz) and the per-pulse energy can be raised by the same factor at the same average power of output radiation. Recently, a further increase of mode-locked laser cavity length by approximately an order of magnitude was demonstrated (Kobtsev *et al*, 2008c). As a result, a stable mode-lock regime was achieved in a fibre laser with optical length of the cavity 3.8 km. In these experiments, a laboratory sample of a ring Yb fibre laser was used, its diagram being shown in Fig. 1. Pumping of a 7-m active Yb-doped fibre with a 7- $\mu\text{m}$  core was performed (Grudin *et al*, 2004) with a 980-nm laser operating at up to 1.5 W of CW output power. The Yb-doped GTWave fibre used in the laser is a convenient choice because it allows using inexpensive diode lasers with multi-mode 100- $\mu\text{m}$  output fibres for pumping. Microscope objectives were employed in order to guide radiation in and out of the free-space laser resonator with discrete elements. The ring configuration of the free-space portion of the resonator was formed by three broadband ( $\Delta\lambda \sim 100$  nm) highly reflective mirrors. Coupling of radiation out of the resonator was done with a polarisation beam splitter that also ensured linear polarisation of the output radiation. Laser generated unidirectional radiation pulses despite the fact that no optical diode was used in the resonant cavity. The propagation direction of the generated pulses coincided with that of the pumping radiation inside the active fibre.

Mode locking of the laser was achieved by using the effect of non-linear rotation of radiation polarisation (C.J. Chen *et al*, 1992; Matsas *et al*, 1992; Chong *et al*, 2008). Control over the polarisation was carried out with the help of three phase plates inserted into the laser cavity. Upon initial alignment of these plates and start of mode locking, this operation was henceforth self-activated as soon as pumping was switched on.

In this experiment the laser cavity comprises no elements with negative (anomalous) dispersion in the spectral range of generation. Mode-locked generation was achieved in an all-positive-dispersion laser configuration. At the minimal length of the resonator 9.4 m, the laser generated single chirped pulses with 3.5-ps duration (Fig. 2(a)) and 300-mW average output power at 1075 nm. The pulse repetition rate was 22 MHz, the spectrum width being 2 nm. Extra-cavity pulse compression by two diffraction gratings (1,200 lines/mm, spaced by  $\sim 15$  mm from each other) lead to reduction of the output pulse duration to 550 fs (Fig. 2(b)). The product  $\Delta\nu\Delta\tau \sim 0.33$  demonstrates that the compressed pulses were transform-limited. The highest per-pulse energy reached 14 nJ. It is relevant to note that a stable mode-locked operation of this laser was achieved without using any additional elements for limitation of laser radiation spectrum, unlike it was reported by (Chong *et al*, 2006) and (Chong *et al*, 2007). In order to elongate the laser cavity a 2.6-km stretch of All-Wave (Lucent) fibre was used. This physical length of the fibre corresponds to the 3.8 km optical length of the laser cavity. The laser diagram with elongated cavity is given in Fig. 3. Pumped with the same amount of power (1.5 W), the laser generated unchanged average output radiation power, 300 mW. However, mode-locked operation of this laser with ultra-long cavity behaved differently depending on the adjustment of the phase plates (Fig. 4).

It was possible to run the laser stably both in the mode of single nanosecond pulses (Fig. 4(a)) or in that of nanosecond pulse trains (Fig. 4(b)), as well as in the mode of nanosecond pulses with noticeable microsecond pedestal (Fig. 4(c)). When generating trains of nanosecond pulses, the train duration was up to 300 ns and the train contained up to 20 pulses, each about 1 ns long. When generating single nanosecond pulses, their duration was 3 ns, repetition rate 77 kHz, and per-pulse energy 3.9  $\mu\text{J}$ . To the best of our knowledge, the energy of pulses we have generated (3.9  $\mu\text{J}$ ) is the highest to-date achieved directly from a

mode-locked fibre laser without application of Q-switching or/and cavity dumping techniques.

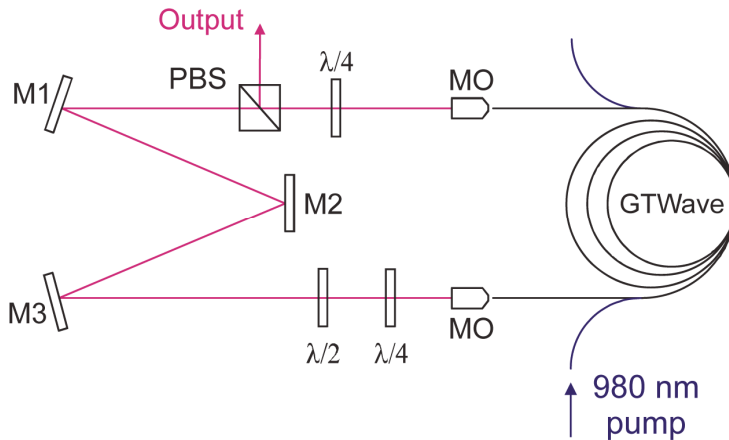

Fig. 1. Schematic of the fibre laser: MO – microscope objective, PBS – polarizing beam splitter, M1-M3 – high-reflectivity mirrors,  $\lambda/4$  – quarter-wave plate,  $\lambda/2$  – half-wave plate.

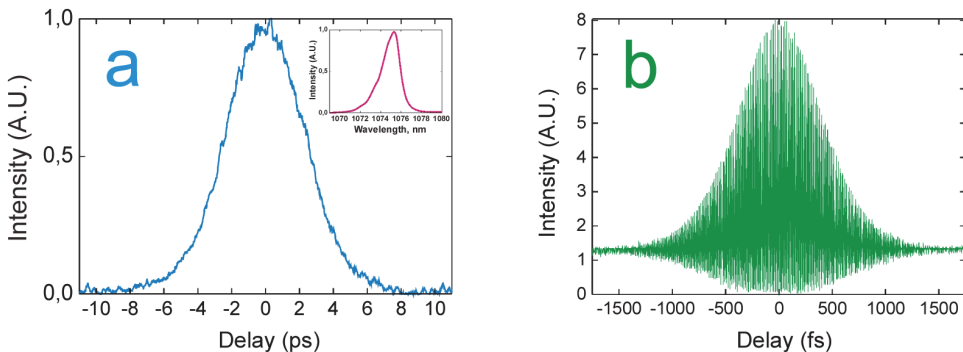

Fig. 2. (a) Background-free autocorrelation trace of chirped pulses from laser output, inset: optical spectrum of the laser; (b) Interferometric autocorrelation trace of de-chirped laser pulses.

In Fig. 5, the radiation spectra of ultra-long mode-locked laser generating single pulses and multiple pulse trains are shown. It can be seen that the width of the spectra differs significantly. The spectrum width of laser radiation in the case of single pulses (Fig. 5(left)) amounted to 0.35 nm, suggesting that the obtained pulses can be subsequently compressed into picosecond range, which possibility, however, was not experimentally verified in this study. Spectrum width of the multiple pulse train radiation (Fig. 5(right)) was almost 20 nm and this indicates that these pulses have different radiation wavelengths. Radiation spectra



of these pulses overlap and form relatively wide resulting spectrum. Note an approximately 11-nm shift of laser spectrum into the long-wavelength range in the case of multiple pulse train generation. Laser spectra of single pulse radiation both in short and in ultra-long cavity are quite smooth-shaped and they exhibit no steep wings with peaks at the edges, which are typical for all-normal dispersion fibre lasers with strong spectral filtering.

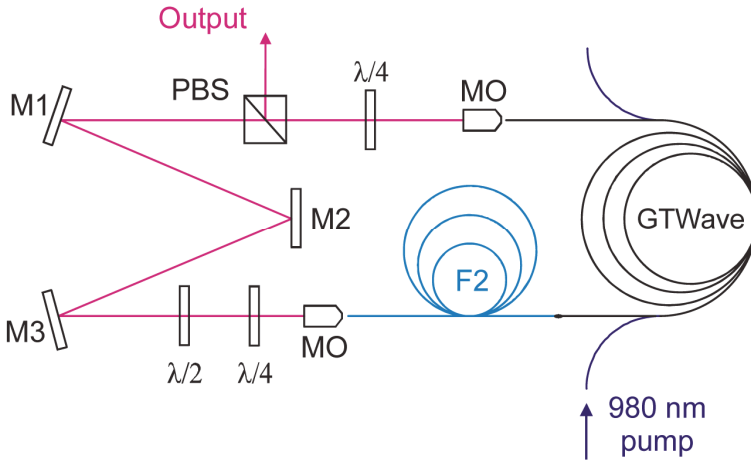

Fig. 3. Schematic of extra-long mode-locked fibre laser: F2 – All-wave fibre, length of 2,6 km.

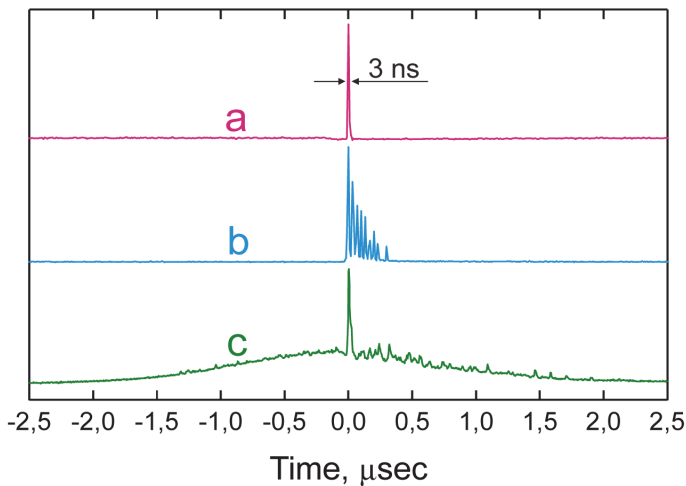

Fig. 4. Temporal distribution of laser radiation intensity in different types of mode-locked operation: a – generation of single 3-ns pulses, b – generation of multiple nanosecond pulse trains, c – generation of single nanosecond pulses with noticeable microsecond-long pedestal. For all types of operation the pulse period (or period of pulse trains in case b) was  $\sim 13 \mu\text{s}$ .

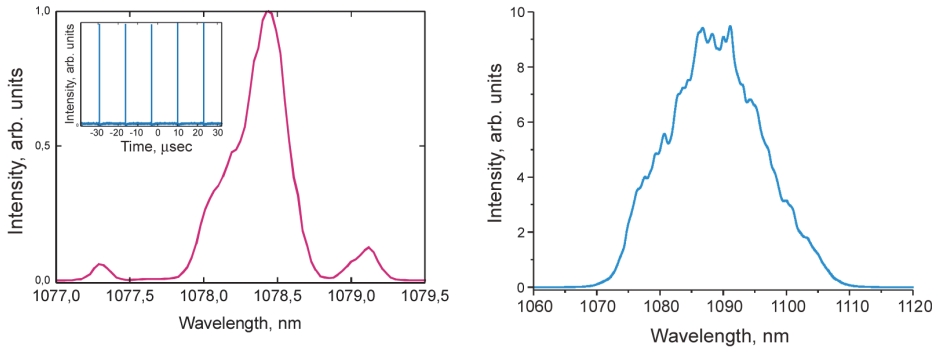

Fig. 5. Optical spectra of the ultra-long mode-locked Yb-doped fibre laser. On the left: spectrum in the case of single 3-ns pulses generation, inset: real-time oscilloscope trace of single pulse train; on the right: spectrum in the case of multiple nanosecond pulse train generation.

New results obtained in the experiments (Kobtsev *et al.*, 2008c) with relatively high energy of pulses directly in a passively mode-locked laser stimulated further investigations in this area (Tian *et al.*, 2009; Zhang *et al.*, 2009; Lin *et al.*, 2011; Song *et al.*, 2011; Ai *et al.*, 2011; Tian *et al.*, 2009; Kobtsev *et al.*, 2009; Senoo *et al.*, 2010; Kelleher *et al.*, 2009; L. Chen *et al.*, 2009; Wang *et al.*, 2011; Nyushkov *et al.*, 2010; Kobtsev *et al.*, 2010a; Ivanenko *et al.*, 2010). In particular, demonstrated experimentally in (Kelleher *et al.*, 2009) were 1.7-ns-long pulses with a giant chirp generated in 1,2-km-long fibre laser mode-locked due to nanotube-based saturable absorber. The time-bandwidth product was about 236, which was  $\sim 750$  times the transform limit, assuming a  $\text{sech}^2$  profile. In (Senoo *et al.*, 2010), passive mode-lock regime was also used in a full-PM fibre cavity of novel  $\theta$ -configuration with the use of saturable absorber (single-wall carbon nanotubes). Generation in an ultra-long cavity with anomalous dispersion was reported in (Li *et al.* 2010). In (L. Chen *et al.*, 2009; Tian *et al.*, 2009), a mode-lock regime was obtained in an ultra-long laser with semiconductor saturable absorber mirrors. In (Kobtsev *et al.*, 2009), a numerical and analytical study of different generation regimes and mechanisms of switching between them was reported for lasers passively mode-locked due to nonlinear polarisation evolution (NPE).

### 3. Applications of high-energy pulses

Despite the fact that studies of long-cavity mode-locked fibre lasers with high-energy pulses have started only recently, these lasers have already found interesting practical applications. The first applications of such lasers were demonstrated in high-energy super-continuum (SC) generation (Kobtsev *et al.*, 2010c).

One of the most obvious approaches to the generation of high-energy super-continuum pulses is based on an increase in the peak power of the pumping pulses (e.g., using several amplification stages). Note that the spectral broadening grows as the pumping power increases, since the super-continuum generation results from the simultaneous action of several non-linear optical effects. However, the corresponding energy losses due to the stimulated Raman scattering and the linear loss related to the propagation in optical fibre also become larger. Thus, the output super-continuum power is saturated at higher

pumping powers, so that a further increase in the pumping power does not lead to a corresponding increase in the super-continuum power (J.H. Lee, 2006). Therefore, alternative methods are required for a further increase in the SC pulse energy. It is highly desirable to supply longer pump pulse duration rather than higher peak power and this can be very naturally implemented with the novel long cavity all-fibre all-positive-dispersion lasers.

Figure 6 demonstrates the diagram of the discussed long-cavity all-fibre ring laser. The Yb fibre that is free of linear birefringence and that is cladding-pumped by means of a multimode coreless fibre serves as the active medium (Grudinin *et al*, 2004). The length of the Yb-doped active fibre is 10 m, and the core diameter is 7  $\mu\text{m}$ . The active fibre is pumped by a multimode diode laser with an output power of up to 1.5 W at the wavelength of 980 nm. The mode locking results from nonlinear polarisation evolution (NPE). An increase in the cavity length using an SMF-28 fibre leads to a decrease in the pulse repetition rate and hence, to a respective increase in the pulse energy at the same mean power.

The demonstrated laser makes it possible to generate pulses with duration of 10 ns and energy of 4  $\mu\text{J}$  at the repetition rate of 37 kHz. The mean output power (150 mW) is limited by the working range of the fibre polarisation splitter that provides the out-coupling of radiation. The FWHM of the pulse spectrum is 0.5 nm, and the corresponding duration of the bandwidth-limited pulse is 2 ps. This indicates the gigantic chirp of the generated 10-ns pulses. Note that single-pass dispersion broadening of 2-ps bandwidth-limited pulses resulting in 10-ns pulses is possible in the SMF-28 fibre with a length of about 500 km. In the laser, the significant pulse broadening is reached at a substantially smaller cavity length (8 km).

For a further increase in the pump-pulse energy, we employ an additional amplification stage based on a cladding-pumped Yb-doped fibre (Grudinin *et al*, 2004). The energy of the amplified pulses is 80  $\mu\text{J}$ , and the mean power of the amplified radiation is 3 W, the 10-ns pulse duration remaining unchanged. The amplified pulses are fed to a 30-m segment of SC-5.0-1040 micro-structured fibre, where the SC radiation is generated in the spectral range 500–1750 nm. (Note that the measurements are limited by the optical spectrum analyser at the long-wavelength boundary.) The spectrum of the SC radiation at the exit of the fibre exhibits a high-intensity peak in the vicinity of the pumping wavelength, which is also typical of the SC in the case of the CW pumping (Kobtsev & Smirnov, 2005). The presence of such a peak is related to an extremely high probability of low-energy soliton generation upon the decay of the continuous wave or the long pumping pulse owing to modulation instability (note the L-shaped distribution of solitons with respect to energy (Dudley *et al*, 2008). No self-frequency shift is observed for low-energy solitons with a relatively low peak power. Therefore, a significant fraction of the input energy remains unconverted and the spectral peak emerges in the vicinity of the pumping wavelength. Another feature of the SC spectrum (Fig. 7) that is important for several practical applications is the presence of a wide plateau in the spectral interval of 1125–1550 nm. Within this interval, the SC power spectral density is varied by no more than 1 dB.

In the above mode of SC generation using nanosecond pumping pulses, the temporal structure of the output pulses is retained on the pulse time scale in contrast to the generation mode using femtosecond and picosecond pumping. Indeed, the SC generation under femtosecond pumping in the range of the anomalous dispersion is initiated by the decay of input pulses into a series of solitons whose duration also falls into the femtosecond range (Kobtsev & Smirnov, 2008b). During the subsequent spectral broadening, the solitons

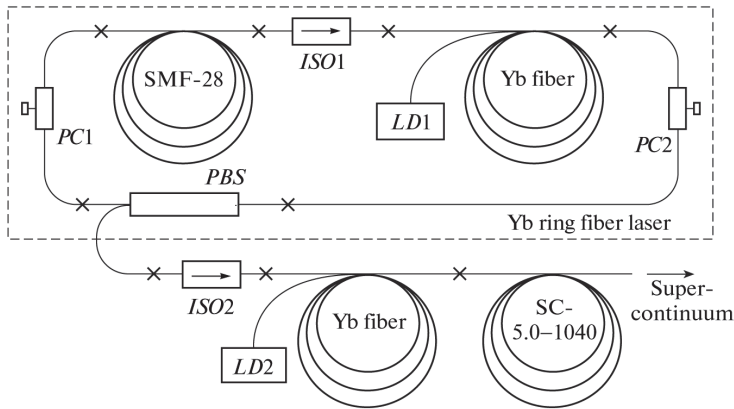

Fig. 6. Schematic layout of the all-fibre SC generator: LD1, LD2 – pumping laser diodes, PC1, PC2 – fibre polarisation controllers, ISO1, ISO2 – polarisation-insensitive optical isolators, and PBS – fibre polarisation beam splitter.

are spread in time and give rise to a wave packet with a complicated temporal structure, such that the duration of the wave packet can be greater than the duration of the femtosecond pumping pulses by a factor of tens. In the case of picosecond pumping pulses, the initial stage of SC generation is characterised by the development of modulation instability, so that the picosecond pumping pulses decay into a stochastic series of sub-pulses (solitons) (Kobtsev & Smirnov, 2008b), whose duration (10–100 fs) depends on the pumping power and the dispersion of the fibre. As in the case of femtosecond pumping, the propagation of soliton sub-pulses along the fibre is accompanied by a temporal spread owing to the group-velocity dispersion. The duration of the resulting wave packet of SC radiation can be several times greater than the duration of the picosecond pumping pulses.

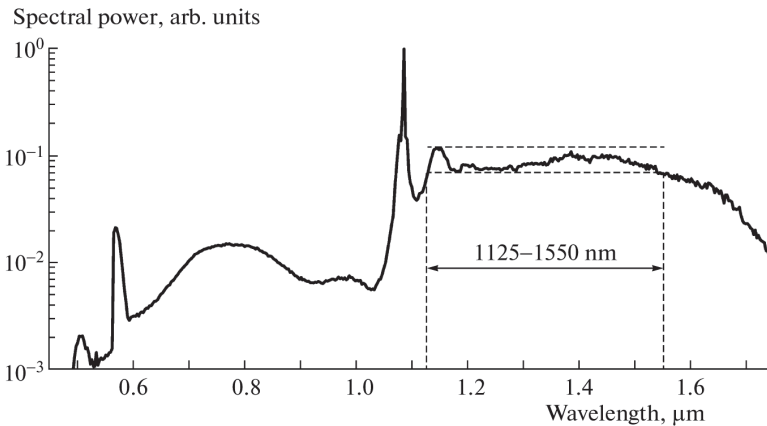

Fig. 7. Spectrum of high-energy SC.

Similar processes induced by the modulation instability and the decay of the excitation pulses into soliton sub-pulses correspond to SC generation in the presence of nanosecond pumping.

In contrast to the femtosecond and picosecond scenarios, the pulse duration at the entrance of the fibre is significantly greater than the characteristic spread of the SC soliton components, so that the duration of SC wave packets at the exit of the fibre is almost the same as the pumping pulse duration. Figure 8 illustrates this effect by presenting the results of numerical modelling of the solution to the generalized nonlinear Schrödinger equation for the pumping pulse with duration of 1 ns and energy of 50  $\mu\text{J}$  in a 30-cm long SC-5.0-1040 micro-structured fibre. To reduce the computation time, we set the pump-pulse duration and the fibre length to values that are smaller than the corresponding experimental parameters. It can be seen that the SC radiation at the exit of the fibre represents a complicated wave packet containing a large number of sub-pulses (optical solitons) (see inset to Fig. 8). The duration of such solitons is 10 fs, their peak power being higher than the peak power of the pumping pulses by no less than an order of magnitude. In the course of propagation, the positions of solitons inside the wave packet evolve owing to the fibre dispersion, but the characteristic scale of such variations does not exceed few dozens of picoseconds and the duration of the nanosecond wave packet is generally maintained. In the experimental measurements of the intensity time distribution, single solitons are not resolved and we observe the output power averaged over a large number of them. Note that averaging soliton spectra (Kobtsev & Smirnov, 2005) yields a wide smooth SC spectrum in experiments. Numerical simulations show that the time-averaged power is only weakly varied in the process of spectral broadening, so that the shape of the nanosecond pulse remains almost unchanged during the SC generation.

It is pertinent to note that various types of generation in high-energy mode-locked lasers may substantially differ from each other in their efficiency of spectral broadening and in the shape of their super-continuum spectra (Wang *et al.*, 2011). This circumstance makes the lasers in question particularly interesting from the viewpoint of development of controllable super-continuum generation whose parameters could be changed dynamically in the process of operation.

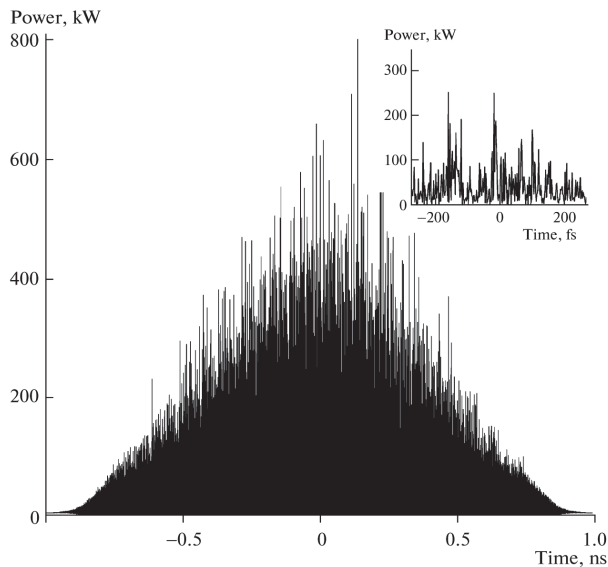

Fig. 8. Numerically simulated plot of the SC radiation intensity *vs* time. The inset shows a fragment of the time distribution on a smaller scale.

#### 4. Underlying physics of high-energy pulse generation

In addition to having record parameters for mode-locked lasers (ultra-low pulse repetition rate, high pulse energy), fibre lasers with greatly extended cavity represent very interesting objects for fundamental physical science. Notwithstanding their relative simplicity of design and of the mathematical models describing them, the lasers with mode-locking achieved due to the effect of non-linear polarisation rotation exhibit an exceptional variety of generation modes and leave unanswered a plethora of questions, which will be the subject of future investigations.

The general principle of mode locking in the considered lasers is rather simple (Hofer *et al*, 1991; Matsas *et al*, 1992; Fermann *et al*, 1993). When travelling along a span of optical fibre, laser pulses with sufficiently high power level will rotate their polarisation ellipse due to the Kerr effect (dependence of the refraction index on the radiation intensity). The rotation angle of the polarisation ellipse determines the radiation losses in the polarisation splitter, the component that couples one of the linearly polarised radiation components out of the cavity. Thus, the optical losses related to the rotation angle of the polarisation ellipse are tied to the radiation intensity. In other words, the optical fibre together with the polarisation splitter form a system that works like a saturable absorber: the losses of the generated pulse inside the polarisation splitter are minimal, but the existing fluctuations are suppressed because of their higher level of losses. In addition to the polarisation splitter and the optical fibre, the laser optical train includes polarisation controllers or phase plates serving for adjustment of the laser (independently of the intensity transformations of the polarisation ellipse).

Two approaches are usually employed for mathematical description of the lasers that make the subject of this study. One of them is based on the solution of a system of coupled non-linear Schrödinger equations for the two orthogonal radiation polarisations. The other one is more heuristic and is based on the solution of the Ginsburg-Landau equation (Haus, 2000).

Both experiment and the numerical modelling demonstrate a great variety of generation modes differing in the number of pulses inside the cavity, in their duration, energy level, in the character of their auto-correlation functions (ACF), as well as in the shape and width of their pulse spectra. The transition of the laser from one generation mode to another may occur both when the pumping power is changed and when the tuning of the intra-cavity polarisation components, – phase plates or polarisation controllers, – is adjusted. The large diversity of possible laser operation modes has not yet been properly catalogued in the literature. A number of attempts to describe different generation regimes have been undertaken (see, for instance (Wang *et al*, 2011)), however the proposed classifications are incomplete. One of the possible systematic descriptions of generation regimes can be done on the basis of their classification according to the pulse-to-pulse stability.

Taking this as a starting point, a vast variety of results produced in experiments and in numerical modelling may be divided into two main types of generation regimes. The first type presents a well-known generation of isolated single pulses (Fig. 9 b, d) with bell-shaped auto-correlation function and steep spectral edges (see Fig. 9 a, c). As the numerical modelling has shown, the pulse parameters obtained in this generation regime are stable and do not change with round trips after approaching those asymptotic values after the initial evolution stage. Since the cavity has all-positive dispersion, the generated laser pulses exhibit a large amount of chirp (Matsas *et al*, 1992; Chong *et al*, 2008; Wise *et al*, 2008) and may be efficiently compressed with an external diffraction-grating compressor, which is confirmed by both the numerical results and the experiment.

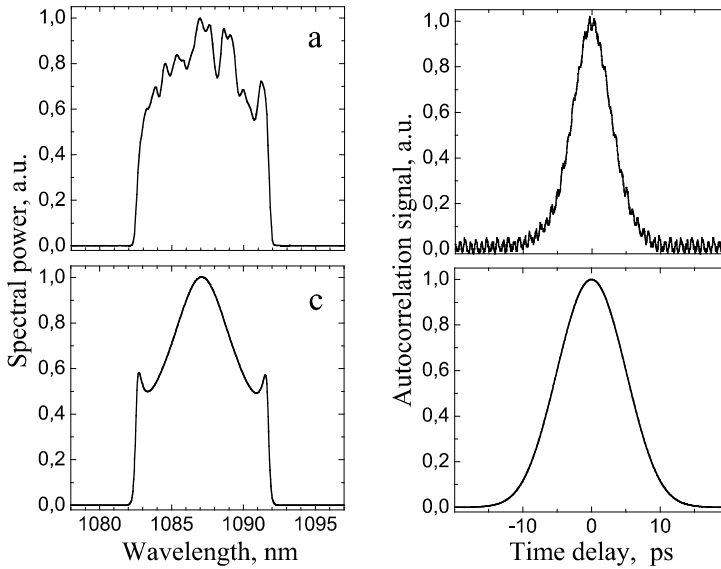

Fig. 9. Stable single-pulse generation: a, b - experimental results; c, d - simulations; a, c - spectra; b, d - ACFs.

It is more interesting, however, that in addition to this standard generation regime, the considered laser scheme also exhibits a different type of operation. In this second mode, an unusual double-structured ACF (femto- and pico-second) can be observed, see Fig. 10 b, e and (Horowitz & Silberberg, 1998). Experimentally measured laser generation spectra of this type usually have a rather smooth bell-shaped appearance (see Fig. 10 a and (Zhao *et al*, 2007)). However, as the numerical simulation demonstrates, such smooth spectra are a result of averaging over a very large number of shorter pulses, whereas the spectrum of an individual pulse contains an irregular set of noise-like peaks (see the un-averaged spectrum in Fig. 10 d shown with a grey line). In the temporal representation this type of generation corresponds to pico-second wave packets consisting of an irregular train of femtosecond sub-pulses (see Fig. 10 f). The peak power and width of such sub-pulses stochastically change from one round trip along the cavity to another, also leading to fluctuations in the wave packet parameters easily noticeable when observing the output pulse train in real time on the oscilloscope screen during experiments (see Fig. 10 c). In other words, such irregular short-scale structures are “breathing” being embedded into a more stable longer-scale pulse envelope. No systematic change in generation parameters such as power or wave-packet duration is observed even after several hours of operation. The absence of systematic drift of pulse parameters is typical for numerical simulations as well (in the latter case, however, much shorter pulse train of about only  $5 \times 10^4$  is examined.) The discussed regime presents an interesting symbiotic co-existence of stable solitary wave dynamics and stochastic oscillations. Note that similar structures have been studied in different context numerically in the complex cubic-quintic Ginzburg-Landau model in (Akhmediev *et al*, 2001; Komarov *et al*, 2005). Generation of short-scale irregular structures could be attributed to wave collapse regimes triggered within certain parameter ranges (Kramer *et al*, 1995; Chernykh & Turitsyn, 1995). The co-existence of stable steady-state pulses and pulsing periodic, quasi-periodic, or

stochastic localised structures is a general feature of multi-parametric dissipative non-linear system (see *e.g.* (Akhmediev *et al*, 2001; Kramer *et al*, 1995) and references therein). Each particular non-linear dynamic regime exists in a specific region of parameter space. Therefore, in systems that possess a capability to switch operation from one region of parameters to another, one can observe very different lasing regimes. The parameter regions where pulsing (periodic, quasi-periodic or stochastic) localized structures do exist might be comparable to or even larger than the regions of existence of conventional steady-state solitons. Note that in the multi-dimensional parameter space of the considered laser scheme, it is almost impossible to explore all the possible operational regimes via direct modelling.

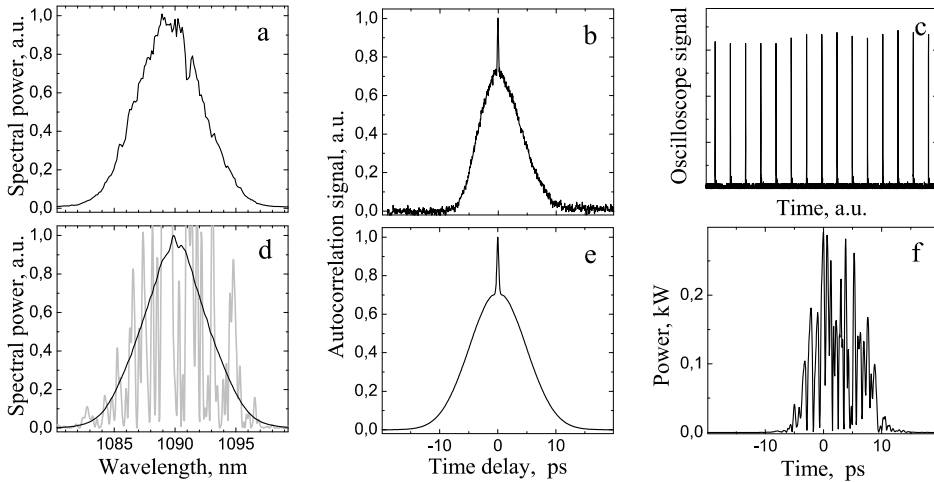

Fig. 10. Quasi-stochastic generation regime: a-c – experimental results; d-f – simulations; a, d – spectra; b, e – ACFs; c – pulse train from oscilloscope; f – non-averaged intensity distribution.

Both experiments and simulations show that wave-packets generated in the double-scale femto-pico-second regime can be compressed only slightly and pulses after compression remain far from spectrally limited. As our experiments have demonstrated, after extracavity compression of these complex wave packets with the help of two diffraction gratings, ACF of the resulting pulses has qualitatively the same double-feature shape. We would like to stress, however, that a possibility of compression is not an ultimate condition that should be imposed on any generated pulses with chirp or having more complex structure. Some applications might even be more appropriate for such double scale pulses with an efficient short scale modulation (irregular) of the longer scale pulse envelope.

Switching between different modes of laser generation can be triggered by changing the parameters of polarisation controllers. In order to clarify the physical mechanisms leading to quasi-stochastic oscillations and mode switching we have carried out massive numerical simulations of laser operation in the vicinity of the boundary of the stable single-pulse generation. While performing numerical modelling, we introduced into the cavity fixed-duration pulses with varying energies and analysed the resulting gain coefficient for the pulse over one complete round trip over the resonator (see black line in Fig 11). At the input power  $P = 1$  (in arbitrary units) the one-trip gain coefficient equals unity, which on the



negative curve slope corresponds to stable generation. Starting with  $P \sim 1.75$  a.u., single-pulse generation becomes unstable (corresponding to positive slope of the black curve in Fig. 11). In this region, an exponential growth of small intensity fluctuations can be observed and, over only several round trips of the cavity, an isolated picosecond pulse is decomposed into a stochastic sequence of femtosecond pulses. Because in this process, a substantial change in the pulse form takes place the gain curves in Fig. 11 no longer correspond to the real situation. Exponential power growth is quickly quenched and over a number of trips along the cavity (as a rule, from dozens to hundreds) an isolated picosecond pulse with stable parameters is formed in the cavity again. So, in our numerical results there was no bi-stability, which could be expected on the basis of the curve shapes in Fig. 11: at any fixed set of cavity parameters only one of the two generation types could be stable irrespective of the initial field distribution within the resonator.

For reliable switching of the generation type it is necessary to adjust polarisation controllers or to change other cavity parameters. For instance, curves 1-3 in Fig. 11 correspond to different resonator length (12.0, 12.3, and 12.6 m accordingly). It can be seen that as the resonator parameters are shifted towards the boundary of single-pulse generation, the width of the stable domain is reduced. Indeed, for curve 3 in Fig. 11 the unity-gain point almost coincides with the extremum, so that even small intensity fluctuations may bring the system into the unstable region and lead to decay of the pulse. If the resonator length is further increased the stable single-pulse generation becomes impossible and the laser starts generating quasi-stochastic wave packets.

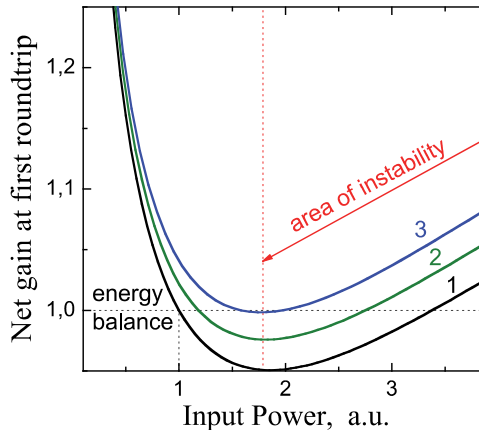

Fig. 11. Net gain per round trip *vs* initial pulse power. Curves 1-3 correspond to slightly different cavity parameters close to boundary of the single-pulse generation regime area.

Conclusions that we drew on the basis of the above analysis are also valid for the effect of generation type switching observed in experiments when changing parameters of polarisation controllers. It should also be noted that the set of curves presented in Fig. 11 for dependence of gain per round-trip on the pulse power is qualitatively very well reproduced in analytical treatment of laser generation, in which every optical element of the laser corresponds to a  $2 \times 2$  unitary matrix.

It is also worth noting that, besides the two above-mentioned basic regimes, intermediate (transient) modes possessing intermediate parameters of their pulse-to-pulse stability can be

observed both in experiment and in numerical modelling. Such modes distinguish themselves in experiment by the height of the peak of their auto-correlation function (the better the stability, the smaller the ratio of the heights of the peak and the pedestal) and by the attainable pulse compression coefficients.

## 5. Prospects and limitations

The mode-locked fibre lasers with high-energy pulses considered in this Chapter are potentially very interesting for a range of practical applications such as *e.g.* super-continuum generation, material processing, and others. Notwithstanding, the practical development of these lasers may be complicated by a number of obstacles that we are going to consider in the following discussion.

As it can be seen from the results of the experimental work and numeric modelling that we have conducted, the advantages and demerits of mode-locked fibre lasers are noticeably sensitive to the cavity length. Therefore, we will consider separately short lasers (with cavity length of several meters), long-cavity fibre lasers (one kilometre and more), and lasers with 'intermediate' resonator lengths.

One of the most important problems of mode-locked fibre lasers with high-energy pulses is related to the stability of generation regimes. The stability of mode locking must be considered at different time scales. First, we consider the time interval between pulses (the round-trip time of the cavity, which is about 1 ns for short lasers) and the laboratory time scale, which corresponds to the period of the laser's continuous operation (one to several hours). The stability of laser pulses over the time scale of the inter-pulse interval is used to identify the above regimes (stable and stochastic). In each case, we will consider the stability over the longer time scale and analyse the time drift of parameters and the spontaneous breakdown of the regime.

The experiments show that relatively short lasers (with cavity lengths of several meters) exhibit stable mode locking on both time scales and provide good pulse-to-pulse stability over several hours. The tuning of the polarisation elements leads to the stochastic regime of lasing, which surprisingly is even more stable than the single-pulse mode locking over long time intervals in spite of the pulse-to-pulse fluctuations. This feature means that the parameters of laser pulses exhibit fluctuations at the pulse repetition rate whereas there is no drift of the mean parameters of such fluctuations in the laser. Evidently, the stability is an important advantage of short lasers with regard to practical applications. The disadvantage of short cavities is relatively low pulse energy, which is insufficient for some applications.

An obvious method to increase the pulse energy involves extra-cavity amplification. However, such an approach necessitates significant complications of the laser setup related to the installation of an additional amplification stage with its optical pumping unit. Note also that a pulse stretcher must be used to avoid the decay of the femtosecond and picosecond pulses during amplification. Such comparative complication of the optical trains for the generation of high-energy pulses justifies the interest in the intra-cavity methods for increasing the pulse energy without any additional amplification stages. A method based on an increase in the cavity length was successfully employed in (Kobtsev *et al*, 2008a,c; Kong *et al*, 2010; Nyushkov *et al*, 2010; Kobtsev *et al*, 2010a, b, c). However, the experiments show that the stability of ultra-long lasers with nonlinear polarisation evolution (NPE) mode locking is lower compared to the stability of short lasers on the time scale of the round trip of the cavity and on longer time scales (about one hour). As a matter of fact, we obtain bell-

shaped laser spectra using long cavities (see, for example, (Kobtsev *et al*, 2008c)), which indicate the stochastic regime of wave packet generation. In contrast to the operation of short lasers, tuning polarisation elements does not allow the transition of ultra-long lasers into the regime of stable lasing, which is characterised by spectra with steep edges. The experimental data are in agreement with the results of the numerical simulation performed using the method from (Kobtsev *et al*, 2010a, Kobtsev *et al*, 2009). In the experiments with cavity lengths greater than 100 m, we failed to observe stable single-pulse lasing, which is characterised by a bell-shaped ACF and a spectrum with steep edges.

Another aspect of the ultra-long laser instability is the spontaneous lasing suppression (stability over long time scales). In comparison to short lasers, ultra-long lasers exhibit more complicated tuning of the polarisation elements required for the realisation of the regime. A typical scenario is a subsequent spontaneous suppression of lasing over a relatively short time interval (no greater than a few hours). The evident physical effects that lead to the above instability are temperature and the polarisation property drifts typical of long fibres along with inelastic deformations of amorphous optical fibre in polarisation controllers.

Thus, both short- (with lengths of several meters) and long-cavity (with lengths greater than 1 km) mode-locked NPE lasers suffer from significant performance disadvantages from the viewpoint of practical applications: short lasers generate only low-energy pulses and the too long-cavity mode-locking lasers fail to provide stable enough single-pulse lasing. This prompted us to look for a possibility of some optimum that could exist in mode-locked lasers featuring intermediate cavity lengths ranging from several dozens to several hundreds of meters.

The experiments demonstrate gradual rather than steep variations in the parameters of lasers at intermediate cavity lengths. In particular, the pulse mean energy increases almost linearly with the cavity length for both the stable single-pulse lasing and the stochastic regime (Kobtsev & Smirnov, 2011). For almost all of the fixed cavity lengths, the mean pulse energy in the stable regime is less than the mean pulse energy in the stochastic regime in qualitative agreement between the experimental data and modelling.

Another parameter that determines the working characteristics of a passively mode-locked NPE laser is the probability of mode-lock regime triggering at random parameters of the polarisation controllers. Figure 12 shows the results of simulation and demonstrates the number of sets of the polarisation parameters that correspond to the stable single-pulse lasing versus the cavity length. The simulation shows that the probability of activation of stable single-pulse mode-locked lasing monotonically decreases with increasing cavity length. For the cavity length of 100 m, only three points that correspond to the stable pulsed lasing are found in the space of the polarisation element parameters. Numerical simulation shows no stable single-pulse regimes for cavity lengths of greater than 100 m. Note that a decrease in the probability of the mode-locking in numerical simulation agrees with a decrease in the stability of the corresponding regime on long time scales in experiment. In fact, a relatively low probability of the stable regime corresponds to a relatively small region in the parameter space associated with a stable lasing. Even minor temperature fluctuations or fluctuations of the parameters of polarisation elements due to fibre deformation are sufficient to break down the corresponding lasing mode in agreement with the experimental data.

Restrictions on the laser pulse length, apart from the generation (in)stability, can limit specific applications of mode-locked fibre lasers with high-energy pulses. Indeed, for

generation of pulses with relatively high energy, lengthening of the resonator is necessary, which, however, leads to increase in the width of generated pulses. In ultra-long lasers with the resonator length about 10 km and more, the duration of the output pulses may be as long as several or even dozens of nanoseconds, thus, being comparable with the pulse duration of Q-switched lasers. This may substantially limit the range of possible applications.

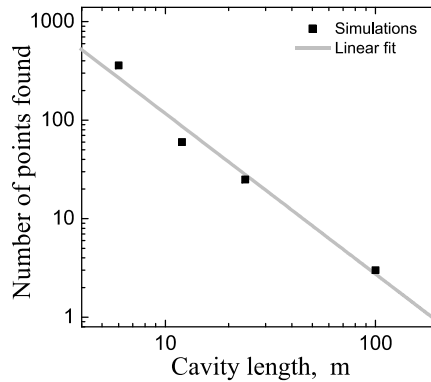

Fig. 12. Plot of the number of points in the parameter space of the polarisation elements that correspond to stable single-pulse lasing in the numerical simulation *vs* the cavity length.

An obvious approach to this problem could be extra-cavity compression of long pulses. In fact, since the resonators of the discussed lasers feature, as a rule, fully normal dispersion, their output pulses may exhibit a considerable amount of chirp, which can be compensated with the help of a compressor. In reality however, such a solution runs into two fundamental difficulties. The first of them comes from the fact that in ultra-long lasers, the pulse chirp may be so high that its compensation becomes technically very difficult or even impossible. The first reason is the absence of standard low-cost fibre-based compressors with anomalous dispersion near 1080 nm, and the second is a more fundamental problem of pulse decomposition in such a fibre due to modulation instability.

Another problem related to pulse compression is the absence of linear chirp in a number of generation modes. For instance, although (Kelleher *et al*, 2009) reports experimentally observed 1.7-ns-long pulses with giant chirp generated in 1.2-km-long fibre laser mode-locked due to nanotube-based saturable absorber, compression of pulses generated in NPE lasers is far from being possible in all the generation regimes. Our experiments and numerical modelling indicate that efficient pulse compression is only possible in a stable generation mode, whereas pulses observed in quasi-stochastic modes of wave packet generation are not easily compressible. In the intermediate (transient) regimes, it may be possible to compress the output pulses by a factor of several units. The shapes of the pulse spectra and of their auto-correlation functions can be used to assess the compressibility of pulses in one or another mode of generation. Efficient compression is only possible, as a rule, in generation regimes characterised by sharp spectrum edges and a bell-shaped auto-correlation function without a narrow peak in the centre.

Thus, the results discussed above indicate a gradual decrease in the stability of lasing associated with a corresponding increase in the cavity length. Stable single-pulse mode-

locked lasing can hardly be achieved in an NPE laser with a cavity length exceeding 100 m. However, the experiments reported by (Kelleher *et al*, 2009) show single-pulse lasing in a cavity longer than 1 km when a saturable absorber is used for mode locking. But even in this case, the question of compressibility of pulses characterised by a giant chirp remains open.

## 6. Conclusions

We have overviewed recent results in a fast developing research area of long-cavity pulsed fibre lasers. Recent research has clearly demonstrated that cavity elongation of mode-locked fibre lasers leads to higher pulse energy directly at the output of the oscillator – up to the level of several  $\mu\text{J}$ . However, the duration of such pulses lies in the nanosecond range and the temporal compressibility of such pulses is yet to be proven. The crux of the problem lies in the fact that, typically, output radiation generated in long resonators has a double-scale form of pulse trains containing sets of sub-pulses rather than that of isolated single pulses. It is this particular feature that distinguishes the output of long mode-locked fibre lasers from that of Q-switched lasers at comparable energies and pulse repetition rates. High-energy nanosecond optical pulse trains filled with stochastic sequences of femtosecond pulses are a hallmark of mode-locked fibre-lasers with ultra-long cavities. We would like to stress that such a very specific temporal characteristic of laser radiation can be used in a variety of applications, including those of Raman amplifier pumping, generation of high-energy super-continuum, material processing, and that this type of output even has advantages over conventional single-pulse radiation in some applications that require temporal modulation of radiation.

## 7. Acknowledgments

This work was partially supported by the Council of the President of the Russian Federation for the Leading Research Groups of Russia, project No. NSh-4339.2010.2; by the Grant “Scientific and educational staff of innovational Russia in 2009-2013” (Grant No II2490); by the Leverhulme Trust and the Marie Curie FP7 Program IRSES.

## 8. References

- Ai, F. *et al* (2011). Passively mode-locked fibre laser with kilohertz magnitude repetition rate and tunable pulse width. *Optics & Laser Technology*, Vol. 43, No. 3 (April 2011), pp. 501-505, ISSN 0030-3992.
- Akhmediev, N., Soto-Crespo, J.M. & Town, G. (2001). Pulsating solitons, chaotic solitons, period doubling, and pulse coexistence in mode-locked lasers: Complex Ginzburg-Landau equation approach. *Physical Review E*, Vol. 63, No. 5 (April 2001), pp. 056602, ISSN 1539-3755 (print), 1550-2376 (online).
- Akhmediev, N. *et al* (2008). Roadmap to ultra-short record high-energy pulses out of laser oscillators. *Physics Letters A*, Vol. 372, No. 17 (April 2008), pp. 3124-3128 (2008), ISSN 0375-9601.
- Ania-Castañón, J. D. *et al* (2006). . Ultralong Raman fibre lasers as virtually lossless optical media. *Physical Review Letters*, Vol. 96, No. 2 (January 2006), pp. 023902-023905, ISSN 0031-9007 (print), 1079-7114 (online).
- Ania-Castañón, J.D. (2009). Design and simulation of ultralong Raman laser links for optical signal transmission. *Proc. SPIE 7386*, 73862J (2009).

- Dudley, J.M., Genty, G. & Eggleton, B.J. (2008). Harnessing and control of optical rogue waves in supercontinuum generation. *Optics Express*, Vol. 16, No. 6 (March 2008), pp. 3644-3651, ISSN 1094-4087.
- Chang, W. *et al* (2008). Dissipative soliton resonances in laser models with parameter management. *Journal of Optical Society of America B*, Vol. 25, No. 12 (November 2008), pp. 1972-1977, ISSN 0740-3224, eISSN 1520-8540.
- Chen, C.J., Wai, P.K.A. & Menyuk, C.R. (1992). Soliton fibre ring laser. *Optics Letters*, Vol. 17, No. 6 (March 1992), pp. 417-419, ISSN 0146-9592 (print), 1539-4794 (online).
- Chen, L. *et al* (2009). Ultra-low repetition rate linear-cavity erbium-doped fibre laser modelocked with semiconductor saturable absorber mirror. *Electronics letters*, Vol. 45, No. 14 (July 2009), pp. 731-733, ISSN 0013-5194.
- Chernykh, A.I. & Turitsyn, S.K. (1995). Soliton and collapse regimes of pulse generation in passively mode-locking laser systems. *Optics Letters*, Vol. 20, No. 4 (February 1995), pp. 398-400, ISSN 0146-9592 (print), 1539-4794 (online).
- Chong, A. *et al* (2006). All-normal-dispersion femtosecond fibre laser. *Optics Express*, Vol. 14, No. 21 (October 2006), pp. 10095-10100, ISSN 1094-4087.
- Chong, A., Renninger, W.H. & Wise, F.W. (2007). All-normal-dispersion femtosecond fibre laser with pulse energy above 20 nJ. *Optics Letters*, Vol. 32, No. 16 (August 2007), pp. 2408-2410, ISSN 0146-9592 (print), 1539-4794 (online).
- Chong, A., Renninger, W.H. & Wise, F.W. (2008). Properties of normal-dispersion femtosecond fibre lasers. *Journal of Optical Society of America B*, Vol. 25, No. 2 (February 2008), pp. 140-148, ISSN 0740-3224, eISSN 1520-8540.
- Fermann, M.E. *et al* (1993). Passive mode locking by using nonlinear polarisation evolution in a polarisation-maintaining erbium-doped fibre. *Optics Letters*, Vol. 18, No. 11 (June 1993), pp. 894-896, ISSN 0146-9592 (print), 1539-4794 (online).
- Fong, K.H. *et al* (2006). Generation of low-repetition rate highenergy picosecond pulses from a single-wall carbon nanotube mode-locked fibre laser. *Optical Amplifiers and their Applications Conference (OAA 2006)*, Whistler, British Columbia, Canada, OMD4, June 2006.
- Fong, K.H., Set, S.Y. & Kikuchi, K. (2007). High-energy ultrashort pulse generation from a fundamentally mode-locked fibre laser at 1,7 MHz, *Proceedings of IEEE/OSA Optical Fibre Conference (OFC) 2007*, Anaheim, 2007.
- Grudinin, A.B. *et al* (2004). Multi-fibrearrangements for high power fibre lasers and amplifiers. United States Patent 6826335, 30.11.2004.
- Haus, H.A. (2000). Mode-locking of lasers. *IEEE Journal of Selected Topics in Quantum Electronics*, Vol. 6, No. 6 (December 2000), pp. 1173-1185, 1077-260X.
- Hofer, M. *et al* (1991). Mode-locking with cross-phase and self-phase modulation. *Optics Letters*, Vol. 16, No. 7 (April 1991), pp. 502-504, ISSN 0146-9592 (print), 1539-4794 (online).
- Horowitz, M. & Silberberg, Y. (1998). Control of noiselike pulse generation in erbium-doped fibre lasers. *IEEE Photonics Technology Letters*, Vol. 10, No. 10 (October 1998), 1389-1391, ISSN 1041-1135.
- Ivanenko, A. *et al* (2010). Mode-locking in 25-km fibre laser, *Proceedings of 36<sup>th</sup> European Conference on Optical Communication (ECOC)*, ISBN: 978-1-4244-8536-9, Torino, Italy, September 2010.
- Jabczyński, J. K. *et al* (2006). Q-switched mode-locking with acousto-optic modulator in a diode pumped Nd:YVO<sub>4</sub> laser. *Optics Express*, Vol. 14, No. 6 (March 2006), pp. 2184-2190, ISSN 1094-4087.

- Johnson, R.H. *et al.* Mode-locked cavity-dumped laser. United States Patent 3995231, 30.11.1976.
- Kang, J.U. *et al.* (1998). Demonstration of supercontinuum generation in a long-cavity fibre ring laser. *Optics Letters*, Vol. 23, No. 17, pp. 1375-1377, ISSN 0146-9592 (print), 1539-4794 (online).
- Kelleher, E.J.R. *et al.* (2009). Generation and direct measurement of giant chirp in a passively mode-locked laser. *Optics Letters*, Vol. 34, No. 22 (November 2009), pp. 3526-3528, ISSN 0146-9592 (print), 1539-4794 (online).
- Kobtsev, S.M. & Smirnov, S.V. (2005). Modelling of high-power supercontinuum generation in highly nonlinear, dispersion shifted fibres at CW pump. *Optics Express*, Vol. 13, No. 18 (September 2005), pp.6912-6918, ISSN 1094-4087.
- Kobtsev, S.M. & Smirnov, S.V. (2008b). Temporal structure of a supercontinuum generated under pulsed and CW pumping. *Laser Physics*, Vol. 18, No. 11 (November 2008), pp.1260-1263, ISSN 1054-660X (print) 1555-6611 (online).
- Kobtsev, S., Kukarin, S. & Fedotov, Y. (2008a). High-energy Q-switched fibre laser based on the side-pumped active fibre. *Laser Physics*, Vol 18, No. 11 (November 2008), pp. 1230-1233, ISSN 1054-660X (print) 1555-6611 (online).
- Kobtsev, S., Kukarin, S. & Fedotov, Y. (2008c) Ultra-low repetition rate mode-locked fibre laser with high-energy pulses. *Optics Express*, Vol. 16, No. 26 (December 2008), pp. 21936-21941, ISSN 1094-4087.
- Kobtsev, S. *et al.* (2009). Generation of double-scale femto/pico-second optical lumps in mode-locked fibre lasers. *Optics Express*, Vol. 17, No. 23 (October 2009), pp. 20707-20713, ISSN 1094-4087.
- Kobtsev, S.M. *et al.* (2010a). High-energy mode-locked all-fibre laser with ultralong resonator. *Laser Physics*, Vol. 20, No. 2 (February 2010), pp. 351-356, ISSN 1054-660X (print) 1555-6611 (online).
- Kobtsev, S.M. & Kukarin, S.V. (2010b) All-fibre Raman supercontinuum generator. *Laser Physics*, Vol. 20, No.2 (February 2010), pp. 372-374, ISSN 1054-660X (print) 1555-6611 (online).
- Kobtsev, S.M., Kukarin, S.V. & Smirnov, S.V. (2010c). All-fibre high-energy supercontinuum pulse generator. *Laser Physics*, Vol. 20, No.2 (February 2010), pp. 375-378, ISSN 1054-660X (print) 1555-6611 (online).
- Kobtsev, S.M. & Smirnov, S.V. (2011). Fibre lasers mode-locked due to nonlinear polarisation evolution: golden mean of cavity length. *Laser Physics*, Vol. 21, No. 2 (February 2011), pp. 272-276, ISSN 1054-660X (print) 1555-6611 (online).
- Kolev, V. Z. *et al.* (2003). Passive mode-locking of a Nd:YVO<sub>4</sub> laser with an extra-long optical resonator. *Optics Letters*, Vol. 28, No. 14, pp. 1275-1277, ISSN 0146-9592 (print), 1539-4794 (online).
- Komarov, A., Leblond, H. & Sanchez, F. (2005). Quintic complex Ginzburg-Landau model for ring fibre lasers. *Physical Review E*, Vol. 72, No. 2 (August 2005), pp. 025604, ISSN 1539-3755 (print), 1550-2376 (online).
- Kong, L.J., Xiao, X.S. & Yang, C.X. (2010). Low-repetition-rate all-fibre all-normal-dispersion Yb-doped mode locked fibre laser. *Laser Physics Letters*, Vol. 7, No. 5 (May 2010), pp. 359-362, ISSN 1612-2011 (print), 1612-202X (online).
- Kramer, L. *et al.* (1995). Optical pulse collapse in defocusing active medium. *JETP Letters*, Vol. 61, No. 11, pp. 887-892.
- Lee, J.H., Han, Y.G. & Lee, S. (2006). Experimental study on seed light source coherence dependence of continuous-wave supercontinuum performance. *Optics Express*, Vol. 14, No. 8 (April 2006), pp. 3443-3452, ISSN 1094-4087.

- Li, X. *et al* (2010). Long-cavity passively mode-locked fibre ring laser with high-energy rectangular-shape pulses in anomalous dispersion regime. *Optics Letters*, Vol. 35, No. 19 (September 2010), pp. 3249-3251, ISSN 0146-9592 (print), 1539-4794 (online).
- Lin, J.H. *et al* (2008). Stable Q-switched mode locked Nd<sup>3+</sup>:LuVO<sub>4</sub> laser by Cr<sup>3+</sup>:YAG crystal. *Optics Express*, Vol. 16, No. 21 (October 2008), pp. 16538-16545, ISSN 1094-4087.
- Lin, J.H., Wang, D. & Lin, K.-H. (2011). High energy pulses generation with giant spectrum bandwidth and submegahertz repetition rate from a passively mode-locked Yb-doped fibre laser in all normal dispersion cavity. *Laser Physics Letters*, Vol. 8, No. 1 (January 2011), pp. 66-70, ISSN 1612-2011 (print), 1612-202X (online).
- Matsas, V.J. *et al* (1992). Selfstarting passively mode locked fibrering soliton laser exploiting non linear polarisation rotation. *Electronics Letters*, Vol. 28, No. 15 (July 1992), pp. 1391-1393, ISSN 0013-5194.
- Nyushkov, B.N. *et al* (2010). Generation of 1.7-uJ pulses at 1.55um by a self-modelocked all-fibre laser with a kilometers-long linear-ring cavity. *Laser Physics Letters*, Vol. 7, No. 9 (September 2010), pp. 661-665, ISSN 1612-2011 (print), 1612-202X (online).
- Saito, L., Romero, M. & Souza, E. (2010). 48.8 km Ultralong Erbium fibre laser in active mode-locking operation. *Optical Review*, Vol. 17, No. 4 (July 2010), pp. 385-387, ISSN 1340-6000 (print) 1349-9432 (online).
- Senoo, Y. *et al* (2010). Ultralow-repetition-rate, high-energy, polarisation-maintaining, Er-doped, ultrashort-pulse fibre laser using single-wall-carbon-nanotube saturable absorber. *Optics Express*, Vol. 18, No. 20 (September 2010), pp. 20673-20680, ISSN 1094-4087.
- Song, R. *et al* (2011). A SESAM passively mode-locked fibre laser with a long cavity including a band pass filter. *Journal of Optics*, Vol. 13, No. 3 (March 2011), pp. 035201.
- Tian, X. *et al* (2009). High-energy laser pulse with a submegahertz repetition rate from a passively mode-locked fibre laser. *Optics Letters*, Vol. 34, No. 9 (April 2009), pp. 1432-1434, ISSN 0146-9592 (print), 1539-4794 (online).
- Tian, X. *et al* (2009). High-energy wave-breaking-free pulse from allfibre mode-locked laser system. *Optics Express*, Vol. 17, No. 9 (April 2009), pp. 7222-7227, ISSN 1094-4087.
- Wang, L. *et al* (2011). Observations of four types of pulses in a fibre laser with large normal dispersion. *Optics Express*, Vol. 19, No. 8 (April 2011), pp. 7616-7624, ISSN 1094-4087.
- Wise, F.W., Chong, A., & Renninger, W.H. (2008). High-energy femtosecond fibre lasers based on pulse propagation at normal dispersion. *Laser & Photonics Reviews*, Vol. 2, No. 1-2 (April 2008), pp. 58-73.
- Zhang, M. *et al* (2009). Mode-locked ytterbium-doped linear-cavity fibre laser operated at low repetition rate. *Laser Physics Letters*, Vol. 6, No. 9 (September 2009), pp. 657-660, ISSN 1612-2011 (print), 1612-202X (online).
- Zhao, L.M. *et al* (2007). Noise-like pulse in a gain-guided soliton fibre laser. *Optics Express*, Vol. 15, No. 5 (March 2007), pp. 2145-2150, ISSN 1094-4087.